

# DC Power Unit Owners Manual

## Page - Contents

1. Safety
2. Identification
2. Warranty
3. Hydraulic Fluid
3. Maintenance
3. Installation
5. Battery Cable Amp Chart
6. Double Acting Diagrams
7. Single Acting Diagrams
8. Troubleshooting

## Introduction:

Please read this document in its entirety before operating the equipment. Ensure the operator is adhering to the safety precautions at all times.

Failure to follow the safety precautions could result in severe injury or death. Always maintain your power source & power unit to insure trouble free operation.

Please consult the factory or a qualified hydraulic technician before attempting to repair hydraulic equipment. The disassembly of a power unit still under warranty will void the warranty. If you need assistance, please consult the factory.

## **Safety**

This information is intended for use by a service technician who is familiar with hydraulic components & understands the required safety precautions. Please consult factory for any questions that may not be answered in this document.

### **WARNING:**

**IF THE PRESSURE RELIEF SETTINGS ARE TAMPERED WYTH THE WARRANTY IS VOID**

If you perform service on your own Tool Tuff Fluid Power product you must assume responsibility for personal injury or property damage that may result.

Please read full equipment manual before attempting to operate equipment.

## **Safety Precautions**

### • Tampering with relief valve

Tampering or adjusting the relief valve will void warranty and could cause catastrophic failure which could result in equipment damage, severe injury or even death.

**Adjusting the relief valve will not increase flow!**

### • Hydraulic Fittings & Hoses

Always ensure hydraulic lines are not routed around or across sharp edges that may cause chafing and damage to hose.

Never crack or loosen a hydraulic connection under pressure. Doing so can result in a hydraulic injection. Always follow the manufactures torque specifications for fittings and hoses.

Warning: Loosening hydraulic lines under pressure can result in catastrophic failure which could result in equipment damage, severe injury or even death.

Read OEM manual before attempting to operating power unit

### Unit Identification:

Before contacting factory for assistance please insure you have the model code & serial number available.

Fill in the fields below upon receiving or installing the power unit.

Keep this information on or near the equipment, making it readily available when needed.

Model Code:
-------------

Serial Number:
----------------

Pressure Setting
------------------

The Model Code is located on the identification label that is affixed to the reservoir.

The Serial Number is located the end-head/ manifold block (serial number may not be visible after installation)

The pressure setting is located on the identification label that is affixed the reservoir.

If you are having trouble identifying the unit in question, please consult factory for assistance. The model code and serial number are extremely important.

### Warranty

Tool Tuff Direct warrants its power units against defects in design, workmanship and components for a period of 6 months from date of purchase.

Under this warranty Tool Tuff Direct will replace any part of its products, free of charge, only after the product in question has been inspected by Tool Tuff Direct or its subsidiaries; and the part is deemed faulty or a manufacturing defect. This warranty does not apply to any product that has been subject to improper installation, unauthorized modification, alteration or repair. Tool Tuff Direct is not liable for any accident caused by improper operation, maintenance, abnormal conditions or wear from abnormal use.

Tool Tuff Direct shall not be liable for loss of time, manufacturing costs, labor, transport, material, loss of profits, consequential damages (direct or indirect), as a result of defective products.

Tool Tuff Direct responsibility will be limited to the repair or replacement of the defective product or the reimbursement of the price paid at the time it was ordered.

Any warranty claim must be presented within 30 days of the manufacturing defect discovery.

All shipping charges are subject to the outcome of the warranty evaluation. Too/ Tuff Direct is not liable for any damages or loss of product incurred

## Maintenance:

Change hydraulic fluid after initial 100 hours of operation Change hydraulic fluid every 3000 hours or 2 years there after

Check hydraulic fluid level regularly before operation

Recommended fluids

Check electrical connections regularly

Corrosion on all connectors

Battery cables

Load test battery often before use

Cleaning

Never pressure wash or hose down the power unit. The DC motor is not sealed extended exposure to moisture will cause premature motor failure. Spray light amounts of cleaner/degreaser on unit and dry with compressed air and/or rag.

Cleaning reservoir breather cap

Remove red cap from breather cap and clean filter element with dishwashing soap & water. Make sure the filter element is completely dry before installing back in the breather cap

## Installation:

### I. Location

Power unit should be mounted either in an enclosure or a location

✓ preventing the unit from being exposed moisture and weather.

Units with Poly reservoirs should

✓ never be mounted in a location where the reservoir is exposed to direct sunlight.

Mount unit as close to the battery as possible.

Reference battery cable selection chart to ensure the proper gage cable has been selected for power unit location

## Hydraulic Fluid:

Hydraulic fluid selection & regular fluid inspection is very important to increase the life of your hydraulic system. The function of Hydraulic fluid is to transfer power from the gear pump to the actuator, weather it is a hydraulic motor o Cylinder.

Selecting the proper fluid viscosity is very important. Selecting a fluid that is too thin may not lubricate the gear pump properly, causing premature pump failure. Also selecting a fluid that is too thick will induce load & cause power loss or cavitation causing gear pump failure.

ISO viscosity grades 22 to 46 are recommended. AW-32 is a good place to start. Anti-wear, antifoaming & rust inhibitor additives are recommended.

For colder climates ATF can be used

In extreme cases Mil-5606 fluid can be used Do not use synthetic, biodegradable or water base hydraulic fluids. In most cases these fluids are not compatible with Buna O-rings. Please check fluid compatibility before use.

Tractor hydraulic fluid is not recommended. Most tractor hydraulic fluid has too high of a viscosity & may **not be compatible with Buna O-rings.**

## Recommended Fluid Viscosity Specifications:

ISO Viscosity Grades  
22-46 cst @ 40 °C 22-46 cSt @ 100 °C 4-8

## Recommended Fluid Maintenance:

Change hydraulic fluid after initial 100 hours of operation

Change hydraulic fluid every 3000 hours or 2 years there after

	<p>Check hydraulic fluid level regularly before operation</p>
--	---

For an additional manifold mounted to unit consult equipment mfg. for specifications  
For adjustable O-ring fittings back nut off a few turns, ensuring the O-ring id is not on fittings threads

If thread sealant is required use liquid thread sealant. If Teflon tape must be used; 1.5 to 2 wraps is plenty. Ensure no tape is over the end Of the fitting

#### 4. Electrical

##### **Reference the Battery Cable**

**Selection** to ensure the proper gage battery cable has been selected for power unit location

✓ **Never route electrical**

around or across sharp edges that may cause chafing and damage to cable/wire insulation **Never route electrical** near moving parts that may chafe or pinch cable/wire

##### **Electrical Connections**

When tightening studded electrical connections, the nut only needs to be tight enough to collapse the spring lock washer.

Ensure all spade connections are secure.

Check electrical connect regularly for corrosion and tightness.

##### **Negative Cable from Battery/Ground**

Single terminal DC motors are internally grounded - Connect Negative cable from battery to the side of the DC motor.

Two terminal DC motors have an isolated ground — The Battery cable must be connected to the Ground stud on the DC motor. (the stud with the cable connected to the Start solenoid is the positive stud. The negative wire Will have a ground wire connected to the base of the start solenoid)

#### 5. Filling reservoir

Notice two lined on dipstick of Breather

## 2. Mounting

All Tool Tuff YBZ series DC power units utilize the same bolt pattern-3/8-16 x W' deep, the holes are 3.25 inches apart Torque mounting bolts to 25 ft-lbs-Steel reservoirs larger than 6 liters must be mounted using the support tab/tabs located at the end of the reservoir opposite the DC motor.

Some poly reservoirs may require a support brackets depending the application, please consult Tool Tuff Direct for reconditions.

## 3. Hydraulic Hoses & Connections

### **Never Crack Hydraulic Fitting When Pressurizes**

Cracking hydraulic fittings or hoses under pressure can result in severe injury.

### **If Hydraulic Injection Occurs Seek Medical Attention**

Hydraulic injection may initially resemble a bite or sting

**Never route Hydraulic Hoses** around or across sharp edges that may cause Chafing and damage to rubber insulation

**Never route Hydraulic Hoses** near moving parts that may pinch or chafe rubber insulation Check

### **Check hydraulic hoses regularly**

Check for cracks or wear on hydraulic hoses. If you can see steel braiding your hoses need to be replaced.

### **Always use hoses and Fittings Intended for Use on Hydraulic Equipment**

Consult fitting specifications and relief valve setting when selecting Hoses and Fittings.

All ports are #6 SAE O-ring boss.

Lubricate all O-rings before installation

> The top line indicates maximum fluid

level

The bottom line indicated the minimum fluid level e/ Fill reservoir to the top line on dipstick of breather during initial startup.

Fill reservoir to fill line on dipstick after air has been cycled out of the system

### Startup Procedure

Double check all electrical & hydraulic connections

Run power unit momentarily ensuring the pump is priming & the load has started to move.

If load doesn't move after a few tries reference troubleshooting section — pump not priming

#### Check voltage drop

Connect a volt meter to the power unit not the battery.

Run power unit momentarily the voltage should not drop below 11.4 volts with a full charged battery. With a fully charged battery the maximum voltage drop is 5%

#### Purging air from hydraulic system

Start by cycling the cylinder about

25% Of the full stroke of the cylinder. During and after each stroke keep an eye on the fluid level and condition of the fluid in the reservoir. The fluid level should never exceed 2" from the bottom of the reservoir Check for excessive aeration of the hydraulic fluid. Increase time between cycles if fluid aeration is present.

If excessive aeration persists stop cycling the cylinder, let the unit rest until the air has dissipated from the reservoir then continue cycling.

To reduce the amount of air being reintroducing to the hydraulic system

Let power unit rest between cycles, with each cycle of the cylinder increase the stroke by 25% or less You may need to add fluid to the reservoir after each cycle. Only add fluid when cylinder is retracted

For intermittent duty applications the reservoir volume is sized off the rod volume of the cylinder, plus a percentage to prevent pump cavitation. More down time between cycles will be required when bleeding the system.

Always check battery voltage

Double check hydraulic system

Check all fittings and hoses for leaks If you think you may have one wipe the fluid off & cycle the unit a few times to see if it the potential leak reappears

Make sure all electrical connections are tight

Check fluid level

Check charging system ensuring the battery is able to receive a charge

DC Battery Cable Selection Guide

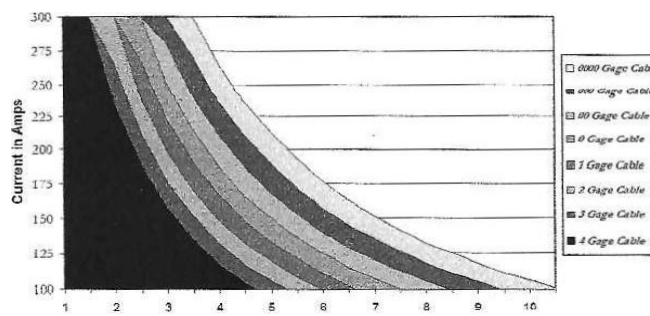

Cable Length in Feet





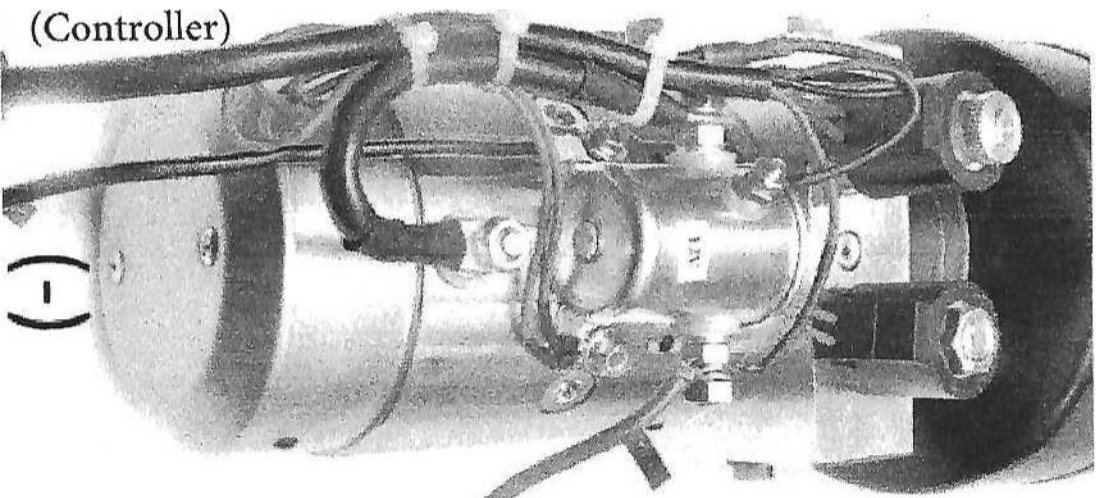

(+) Connect the positive lead from the battery onto the solenoid where the red line from the controller is also connected

(-) Ground the battery to the motor casing. Do not connect it to anything that has another wire connected to it.

(+)

(-)

(Controller)

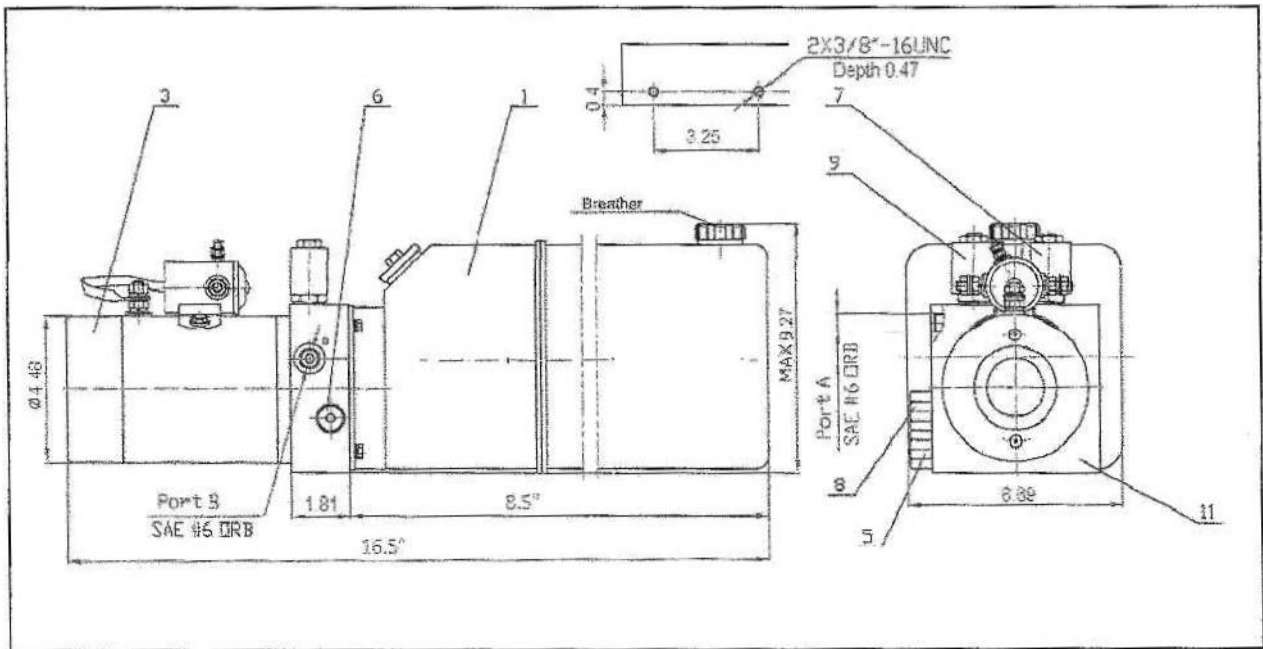
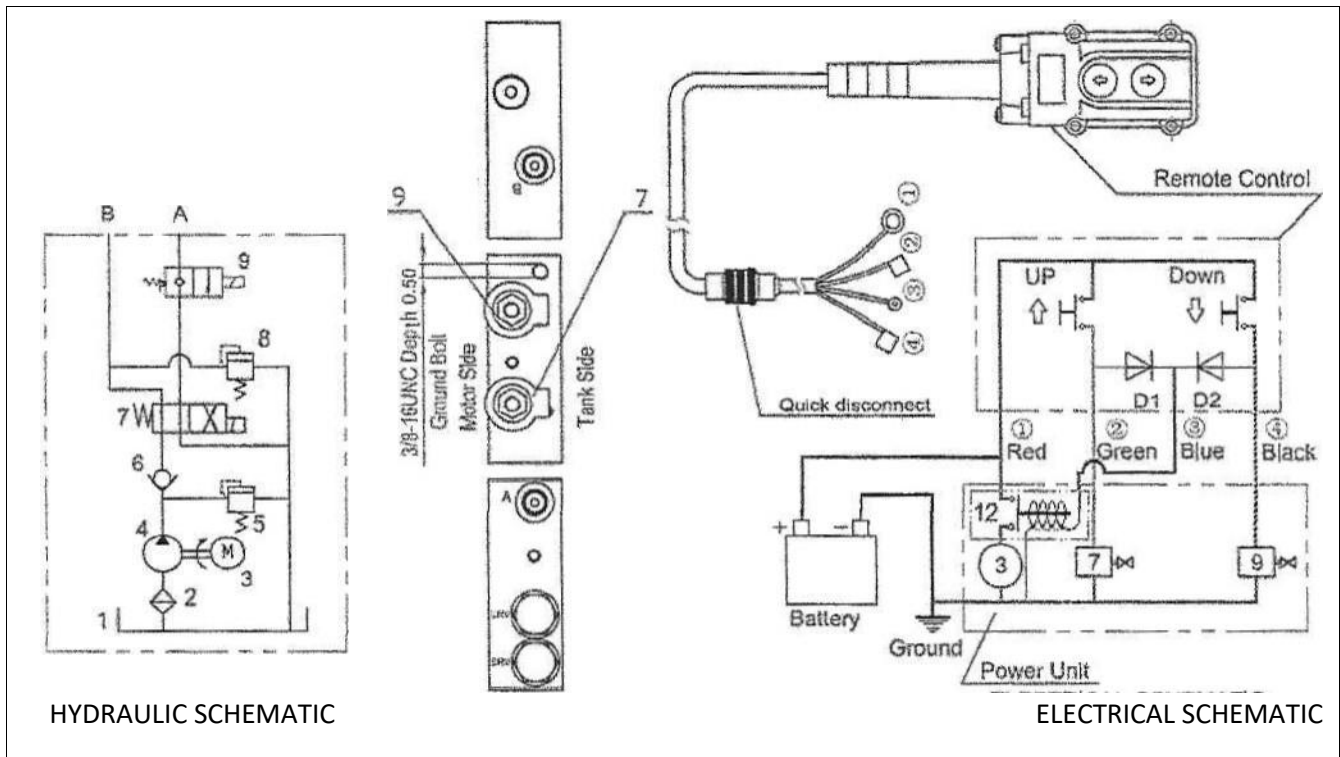

	5 RV-3B-A	system Reliet	3205PSI	12 ss-203Y	
3		Gear pump. C,128 Motor, 12VOC , 2.7HÄ , S3<ety		11	Centre: Menifald Remate CoNrc.S, 25 feet cord
2	YBZ-GI.O-G3?8	Suc%on Filter		9	Remote Control, 25 feet cord Solenoïd Valve 2 Way 2 Position 12VDC
	yeZ-SLYX-6L-N	Steel, 3-5 qt		7	Low Relief valve 2 Way 2 Position 12VDC Low Relief valve , 1500PSI Solenoïd Valve 2 Way 2 Position 12VDC IOVCC

## Single Acting Schematic

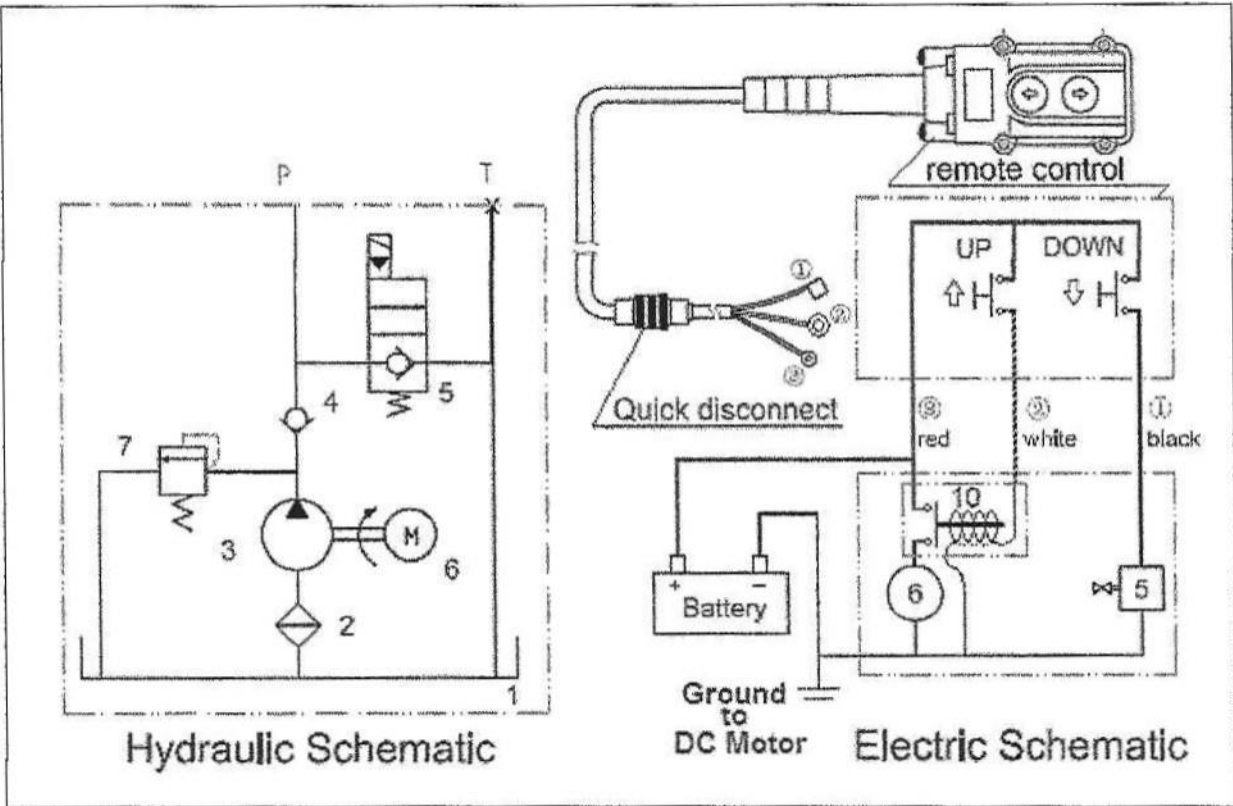
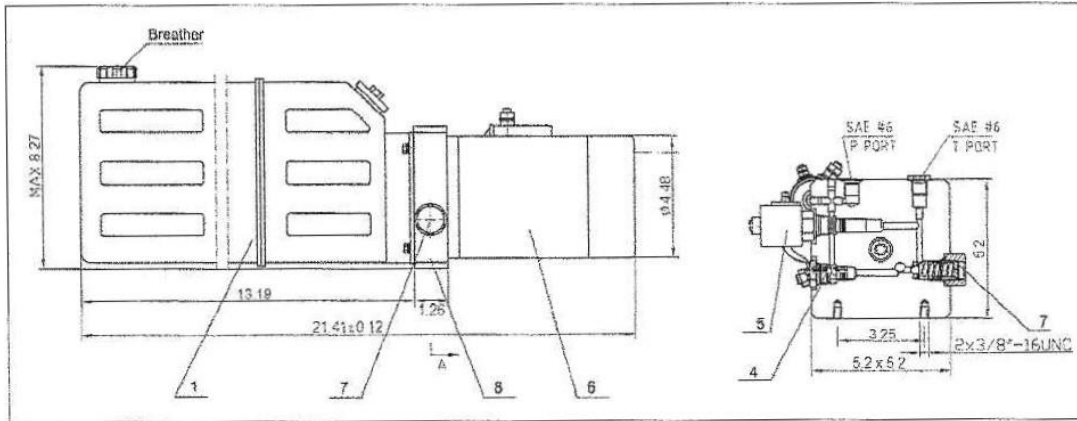

4	DCV-08-2	Check Valve	g	Re-2e3L8M-H	Remote Cntrd 25 feet cord
3	CBK-F21F	Pump. CEK-F-ZIF, 0.12g Cu.infRev		YBZ...=2.ãDIVmNUAAT1-01	Manifold
	YBZ-GLC-G38	Suction filter	7	RV-3,'4-A	Relief Valve, Preset et 3200 PSI

	YBZ-SLYX-GL-N	Regen. •olrr Plastic. Horizontal	6	DM1f-1WWT-3EAIR-SA1	DC Motor, 2.0 HP, f2V.2EQORPM, S3 duty
	TK-36C	Reserv-iz, Steel. garl. ••-ää-1	5	osv.C8-2NCP-sa	Release ICVDC. NC
NO.	Pari Numb*	Descripti			

## Troubleshooting

### Safety

This information is intended for use by a service technician who is familiar with hydraulic components & understands the required safety precautions. Please consult factory for any questions that may not be answered in this document.

#### WARNING:

IF THE PRESSURE SETTINGS ARE  
TAMPERED WITH THE WARRANTY IS VOID

If you perform service on your own Tool Tuff Direct product you must assume responsibility for personal injury or property damage that may result.

Please read full equipment manual before attempting to troubleshoot and make repairs.

### Safety Precautions

#### Tampering with relief valve

Tampering or adjusting the relief valve will void warranty and could cause catastrophic failure which could result in equipment damage, severe injury or even death.

Adjusting the relief valve

Will not increase flow!

#### Hydraulic Fittings & Hoses

Always ensure hydraulic lines are not routed around or across sharp edges that may cause chafing and damage to hose.

Never crack or loosen a hydraulic connection under pressure. Doing so can result in a hydraulic injection. For more information on Hydraulic

Always follow the manufactures torque specifications for fittings and hoses,

Symptoms	Possible Cause	Correction	Special Notes
System Inoperative	Dead or Low Battery	Load test battery	Charge or replace battery
	Poor Ground	Ground battery directly to DC motor	Use jumper cables to jump ground only
	Dirty Contacts in Hand Control	Clean contact in hand control with eraser	Cleaning contacts with abrasive will cause frequent failure
	Corrosion on Battery Terminals	Inspect battery cables & clean battery terminals	use of dielectric grease will prevent corrosion buildup
	Start Solenoid Failure	Jump Start Solenoid	Replace Solenoid
	Rust in DC Motor	Bypass Start Solenoid	If motor doesn't run after bypassing start solenoid, remove rear cover of motor for quick inspection.

Symptoms	Possible Cause	Correction	Special Notes	
Motor Runs Load Not or Cylinder not Extending	Low Battery/ Poor Ground	Load test battery	Charge or replace battery	
	**Bad diode in hand control	Remove coil from directional valve & operate unit. Only 1 valve coil should operate at a time.	Replace diodes inside hand control if 2 coils are operating when pressing up or down button.	
	Dirty Contacts in Hand Control	Clean contact in hand control with eraser	Cleaning contacts with abrasive will cause frequent failure	
	*'Directional Valve Issue	Check for bent valve stem		Replace valve if stem is bent
		Ensure coil is energizing		Double check you are getting power to coil before replacing
		Remove valve and inspect O-rings		Replace a-rings if damaged
		Check cross drilled holes between O-rings of valve for debris		Replace valve if spool is not shifting (for most directional valves the spool will cover half of the cross drilled holes when valve is at its at rest or activated positions)
		Ensure valve is shifting (use dipstick push on valve spool to shift valve. Look through cross drilled holes between O-rings ensuring valve is shifting)		
	Pump Not Priming	*Remove check valve & activate motor momentarily to rime.		Replace gear pump if problem is not solved
		* *Remove check valve plug & activate motor momentarily to prime		
	Relief Valve	If relief valve is bypassing check pressure gage to ensure valve is set at proper setting as marked on power unit		Double check with equipment manufacturer ensuring the manufacturer did not adjust pressure setting at factory.
	Cylinder	"Check to see if fluid is passing through the rod seals to tank		Rebuild or replace the cylinder if fluid is passing through the cylinder without moving the rod
* Check to see if fluid is coming out vent on rod end of cylinder when fully retracted				

Symptoms	Possible Cause	Correction	Special Notes
(*Single Acting) Cylinder Not Retracting	Dead or Low Battery	Load test battery	Charge or replace battery
	Poor Ground	Ground battery directly to DC motor	Use jumper cables to jump ground only
	Coil on Solenoid Valve not Activating	Ensure power is getting to coil, check all electrical connections and Check for magnetism	Replace coil if you are getting power to the coil but it is not energizing.
		Check ground wire or valve stem. For loose connections or corrosion. (If coil is single wire lead, check the contacting point where solenoid rests on valve stem for corrosion)	
		Loose wire in quick connector or control box	
		Clean contact in hand control with eraser	
	Bent stem on solenoid valve	Inspect stem on solenoid valve <b>(DO NOT REMOVE VALVE FOR INSPECTION IF SYSTEM IS UNDER PRESSURE)</b>	Replace valve if stem is bent
	Debris in screen of load holding Valve	Remove load holding valve. Inspect screen & valve for debris. <b>(DO NOT REMOVE VALVE FOR INSPECTION IF SYSTEM IS UNDER PRESSURE)</b>	Load holding valve is below fluid level. Removing this valve will partially drain reservoir.
	Debris in flow control valve	Remove flow control valve & inspect valve for debris.	Top of valve is threaded, use 1/4-20 bolt to remove flow control valve.
	Cylinder issue	Fluid coming out vent on rod end of cylinder	Replace cylinder
Check cylinder alignment		Contact equipment manufacturer if this is an Issue	
Packing in cylinder may have tailed		Contact equipment manufacturer for replacement cylinder	

Symptoms	Possible Cause	Correction	Special Notes
(**DoubleActing) Motor Runs Load Not Moving or Cylinder not Retracting	Dead or Low Battery	Load test battery	Charge or replace battery
	Poor Ground	Ground battery directly to DC motor	use jumper cables to jump ground only
	Coil on solenoid valve not activating	Ensure power is getting to coil, check all electrical connections and check for magnetism	Replace coil if you are getting power to the coil but it is not energizing,
		Check ground Wire or valve stem. For loose connections or corrosion. (If coil is single wire lead, check the contacting point where solenoid rests on valve stem for corrosion)	
		Loose wire in quick connector or control box	
		Clean contact in hand control with eraser	
	Debris in screen of load holding valve (motor would be running and bypassing over relief valve)	Remove load holding valve. Inspect screen & valve for debris. (DO NOT REMOVE VALVE FOR INSPECTION IF SYSTEM IS UNDER PRESSURE)	use dipstick on power unit to manually shift the valve. This is accomplished by inserting the dipstick in the nose of the valve and applying pressure. Replace valve if it doesn't shift.
	Debris in flow control valve if present	Remove flow control valve & inspect valve for debris.	Top of valve is threaded, use 1/4-20 bolt to remove flow control valve.
	Directional Valve Issue	Check for bent valve stem	Replace valve if stem is bent
		Ensure coil is energizing	Double check you are getting power to coil before replacing
Remove valve and inspect O-rings		Replace O-rings if damaged	

		Check cross drilled holes between O-rings of valve for debris	Replace valve if spool is not shifting (for most directional valves the spool will cover half of the cross drilled holes when valve is at its at rest or activated positions)	
		Ensure valve is shifting (use dipstick push on valve spool to shift valve. Look through cross cross drilled holes between O-rings ensuring valve is shifting)		
	Relief Valve	If relief valve is bypassing check pressure gage to ensure valve is set at proper setting as marked on power unit	Double check with equipment manufacturer ensuring the manufacturer did not adjust pressure setting at factory.	
	Cylinder	Check to see if there is hydraulic pressure in the lines	If there is no pressure in lines and cylinder will not retract replace or repair cylinder	
<b>Symptoms</b>	<b>Possible Cause</b>	<b>Correction</b>	<b>Special Notes</b>	
Reservoir Overflows When Lowering	Low fluid level	Add fluid to reservoir when cylinder is fully retracted	Before running power unit insure all air bubbles have dissipated to prevent further aeration of fluid	
	Loose Inlet	Remove reservoir & tighten or replace inlet tube on pump		
	Reservoir too small for hydraulic system	Consult equipment manufacturer for correct reservoir Size		
<b>Symptoms</b>	<b>Possible Cause</b>	<b>Correction</b>	<b>Special Notes</b>	
Unit Struggles to Lift Load	Dead or Low Battery	Load test battery	Charge or replace battery	
	Poor Ground	Ground battery directly to DC motor	Use jumper cables to jump ground only	
	Directional valve not completely shifting**		Check for bent valve stem	Replace valve it stem is bent
			Check cross drilled holes between O-rings of valve for debris	Replace valve if spool is not shifting (for most directional valves the spool will cover half of the cross drilled holes when valve is at its at rest or activated positions)
			Ensure valve is shifting (use dipstick push on valve spool to shift valve_ Look through cross drilled holes between O-rings ensuring valve is shifting)	



	Debris in screen of load holding valve	Remove load holding valve. Inspect screen & valve for debris. (DO NOT REMOVE VALVE FOR INSPECTION IF SYSTEM IS UNDER PRESSURE)	Use dipstick on power unit to manually shift the valve. This is accomplished by inserting the dipstick in the nose of the valve and applying pressure. Replace valve if it doesn't shift.
	Rust in Motor	Bypass Start Solenoid	If motor doesn't run at a higher RPM after bypassing start solenoid, remove rear cover of motor for quick inspection.
	Worn seats in cylinder	Packing on piston of cylinder could be bad and be wedged against bore of cylinder.	Have cylinder tested by certified technician